

TV SERIES-FT 2-1811

EAN 8422202218113



Reinforced nylon castors, especially indicated to support high-loads up to 600kg (1323lb).

It is used in: internal logistics tools, repair shops, tool trolleys, internal logistics, mobile platforms, transport tools, elevating platforms, food industry, transport carts, logistics for military missions material, ladders, packaging machines, conveyor belts, light machinery for the construction, elevating tables, boilers, cabinetmaker's, locksmith's, metalworks, agricultural farms, meat industry, textile and sport centres.

Mainly used in the industrial sector, aeronautic sector and automobile factories.

Suitable for mechanical engineering projects by draftsmen and project executors

FT: castors especially indicated for food and chemical industry applications. Does not leave marks on floor. Reinforced. High resistance to impacts and collisions.

Technical Data

Housing Type	Fixed
Fitting Type	Plate
Braking System	Without Brake
Material	Nylon(Polyamide 6)
Bearing	Plain
Diameter (mm)	125
Width of tyre (mm)	42
Plate dimensions (mm)	136x116
Distance between holes (mm)	105x80
Plate hole diameter (mm)	10
Overall height (mm)	164
Load	600
Unit Weight of the wheel (kg)	1.34
Volume (cm ³)	2644

CAD

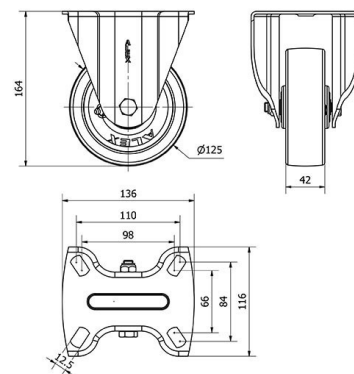

To visualize the image with higher resolution and more technical details, please access to the CAD section

Brackets

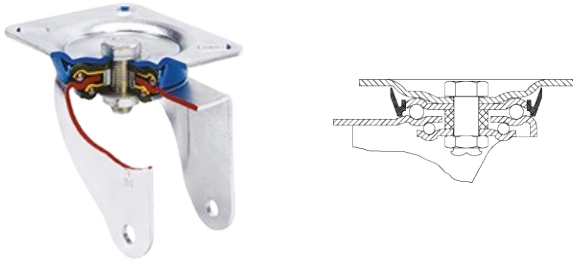

Manufactured with pressed steel up to 5 mm. Highly rust-resistant double-chrome coating. Double ball bearing reinforced with hardened ball races. Dust-proof in the sealing swivel head. Manufactured to European standard EN 12532.

Similar products



2-1800



2-1822

Wheel



Reinforced nylon (Polyamid 6) wheel, white colour
Temperature range: -30° ÷ +80°

Rolling Resistance Excelent

Noise during the march Reasonable

Floor Protection Reasonable