

## TV SERIES-FT 2-1820

EAN 8422202218205



Reinforced nylon castors, especially indicated to support high-loads up to 400kg (882lb).

It is used in: internal logistics tools, repair shops, tool trolleys, internal logistics, mobile platforms, transport tools, elevating platforms, food industry, transport carts, logistics for military missions material, ladders, packaging machines, conveyor belts, light machinery for the construction, elevating tables, boilers, cabinetmaker's, locksmith's, metalworks, agricultural farms, meat industry, textile and sport centres.

Mainly used in the industrial sector, aeronautic sector and automobile factories.

Suitable for mechanical engineering projects by draftsmen and project executors

FT: castors especially indicated for food and chemical industry applications. Does not leave marks on floor. Reinforced. High resistance to impacts and collisions.

### Technical Data

|                               |                      |
|-------------------------------|----------------------|
| Housing Type                  | Swivel               |
| Fitting Type                  | Plate                |
| Braking System                | Wheel Brake And Fork |
| Material                      | Nylon(Polyamide 6)   |
| Bearing                       | Plain                |
| Diameter (mm)                 | 100                  |
| Width of tyre (mm)            | 32                   |
| Plate dimensions (mm)         | 106x86               |
| Distance between holes (mm)   | 86/80x60             |
| Plate hole diameter (mm)      | 8                    |
| Offset (mm)                   | 81                   |
| Overall height (mm)           | 140                  |
| Load                          | 400                  |
| Unit Weight of the wheel (kg) | 1.407                |
| Volume (cm <sup>3</sup> )     | 2336                 |

### CAD

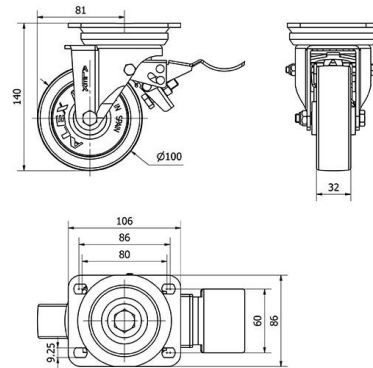

To visualize the image with higher resolution and more technical details, please access to the CAD section

## Brackets

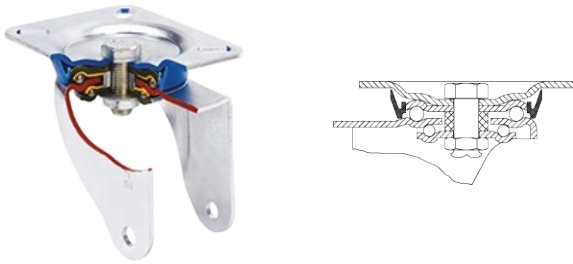

Manufactured with pressed steel up to 5 mm. Highly rust-resistant double-chrome coating. Double ball bearing reinforced with hardened ball races. Dust-proof in the sealing swivel head. Manufactured to European standard EN 12532.

## Similar products



2-1798



2-1809

## Wheel



Reinforced nylon (Polyamid 6) wheel, white colour  
Temperature range: -30° ÷ +80°

Rolling Resistance Excelent



Noise during the march Reasonable



Floor Protection Reasonable

